

ES^{FP}TM

ENERGY SAVER

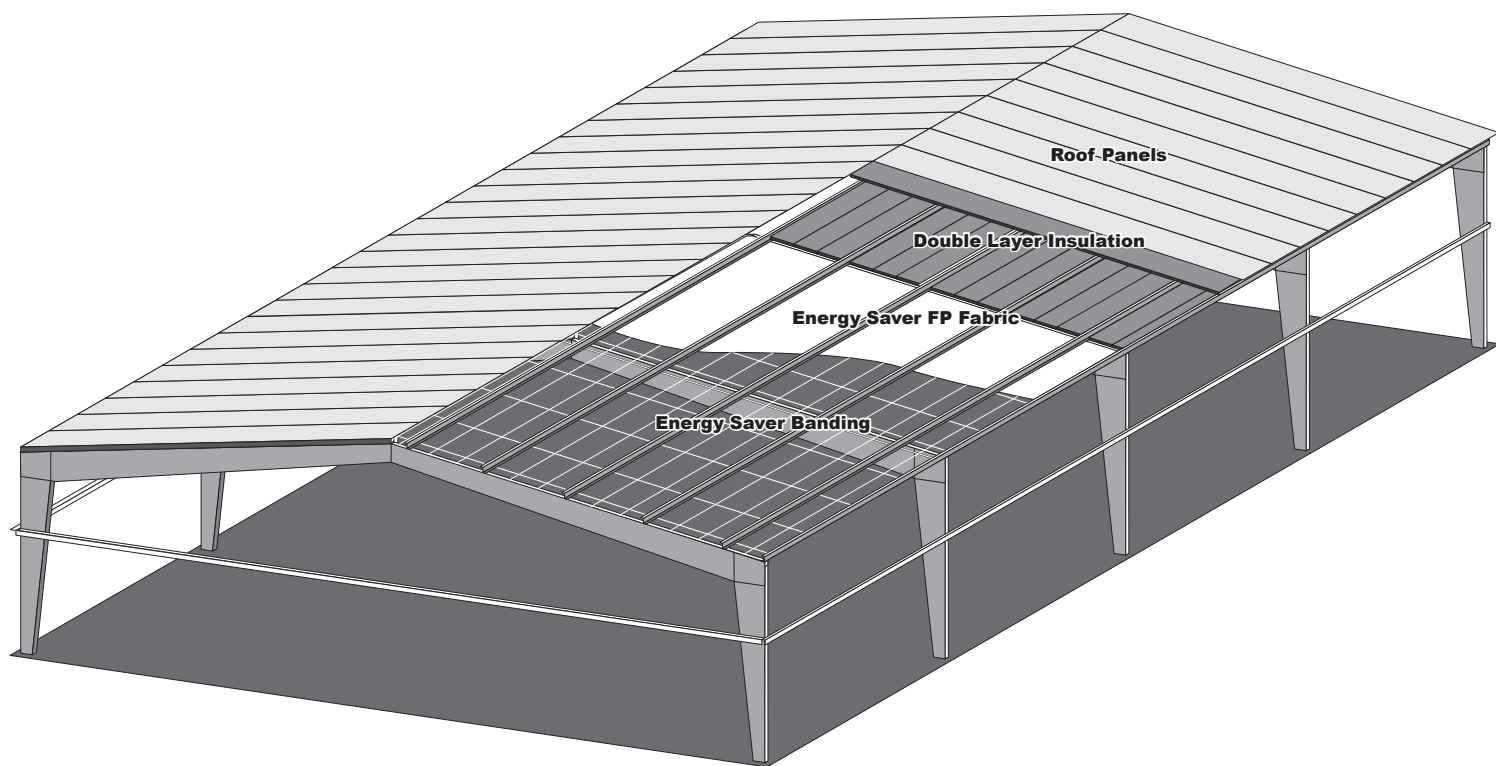

Roof Installation Guide

FOR NEW CONSTRUCTION

Be sure to read the entire instructions before you begin.

1. Parallel Banding Installation

- 1.1** Install a series of parallel (longitudinal) bands within each purlin space. It is required that two bands be installed in the eave and ridge spaces. For the remaining purlin spaces 48" or greater, install two bands per space; for purlin spaces less than 48", install one band per space.

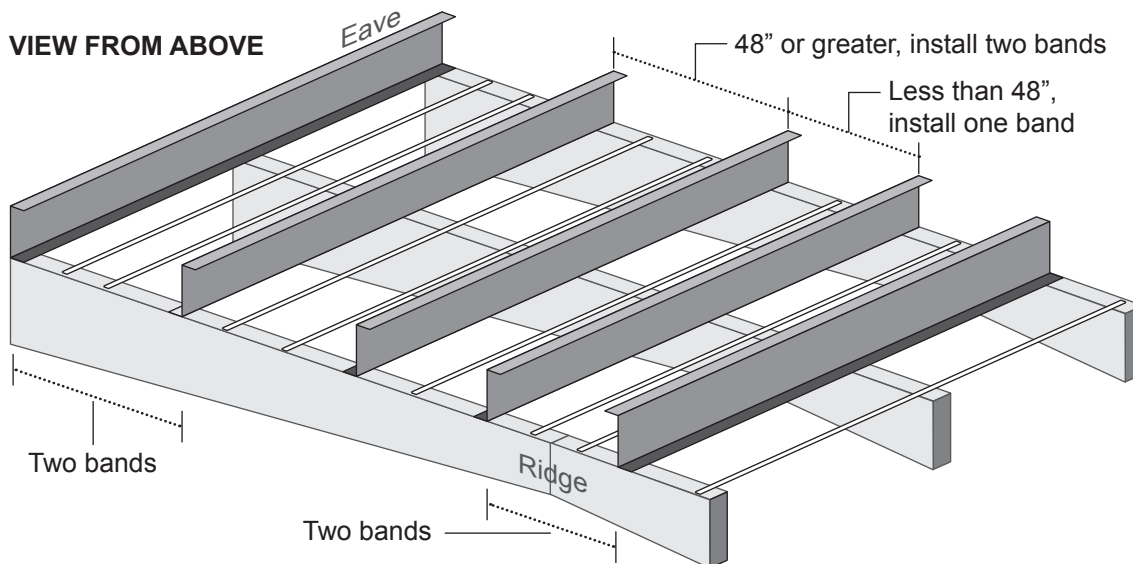

WARNING

- ❗ If your project includes Energy Saver walls, special consideration may be required at eave strut for the roof and wall connection. Determine which wall system you are using then see appropriate technical connection detail available separately Energy Saver roof to Energy Saver wall or Energy Saver roof to MBI walls.
- ❗ Do not splice parallel bands. If the banding is not long enough to install in one piece for the length of the building, follow the instructions in the Technical Detail at page 7 for the proper installation procedure.

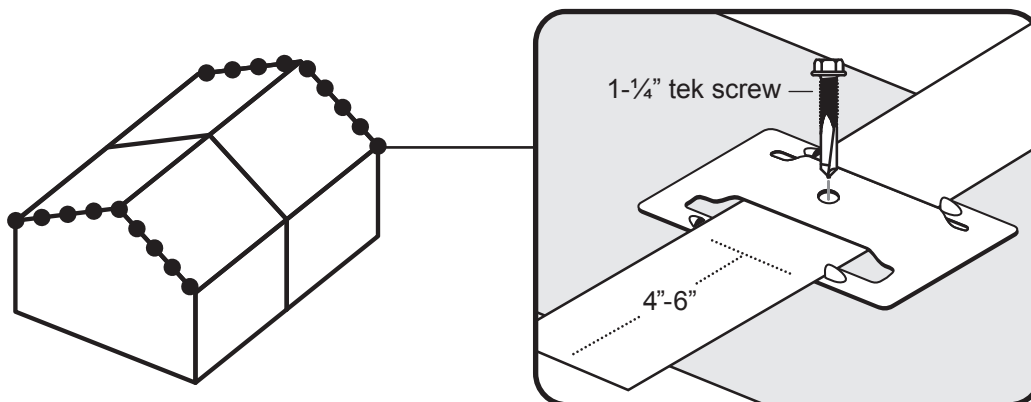

- 1.3** Fasten these bands to the top flange of endwall rafters only, using a single 1-1/4" metal tek screw and banding clip. Pull banding hand-tight to far endwall rafter and secure in the same manner as above.

*Do not fasten parallel bands to intermediate rafters, as the System will not offer leading edge fall protection. If parallel bands are not fastened to intermediate rafters, the system will offer leading edge fall protection within 6'0" of the rafters, provided that the System (fabric included) is completely installed in both bays sharing a common intermediate rafter.

2. Perpendicular Banding Installation

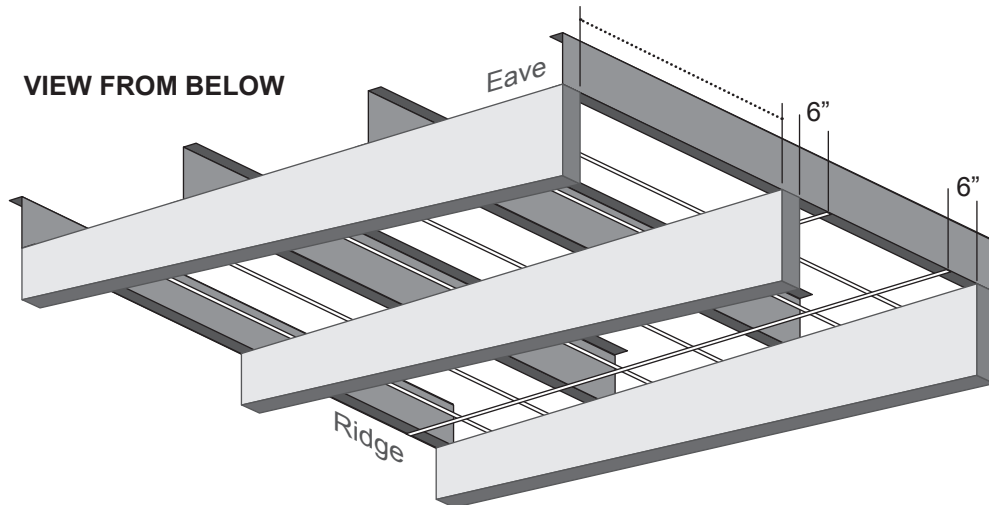

2.1 Starting exactly six (6") inches from the rafter edge install a series of perpendicular (cross) bands to the bottom flange of the eave strut.

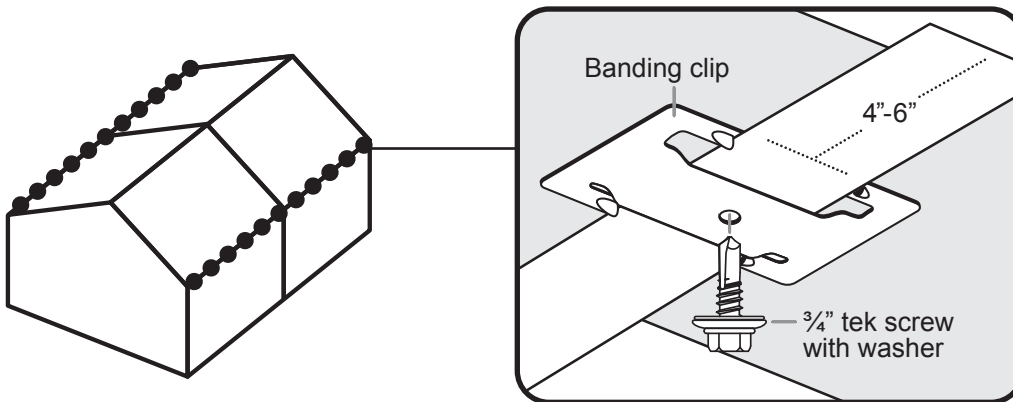

2.2 Fasten these bands to the bottom flange of the eave strut, using a single $\frac{3}{4}$ " metal tek screw and banding clip. Pull banding hand-tight while making sure to remove twists. Insert the steel banding through the banding clip and extend approximately 4-6" beyond the clip. The banding and clip should be fully secured, tightened, and flush with the surface (See Banding Clip detail for technical specifics).

2.3 Remaining perpendicular bands should be evenly spaced no more than 60" inches on center. Bands should be woven above every 6th parallel band and above both bands in the ridge space.

If perpendicular banding splicing is required, refer to Energy Saver Banding Field Splice Detail (in this document).

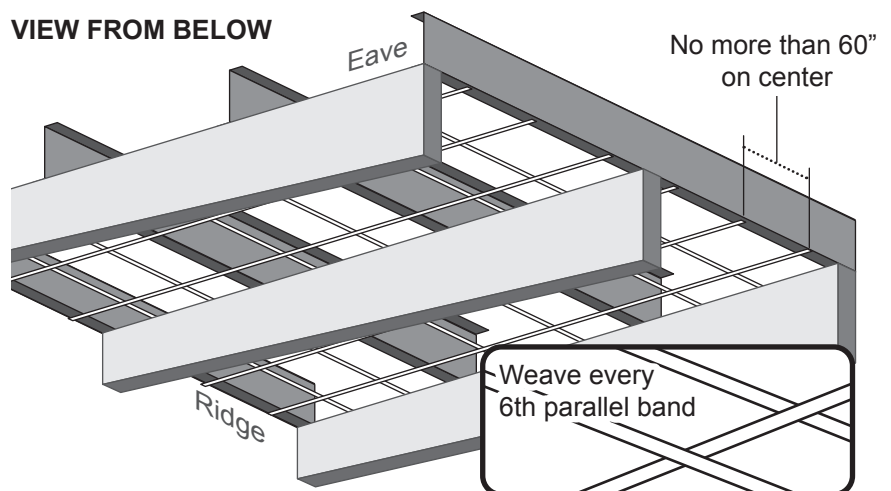

3. Fabric Installation

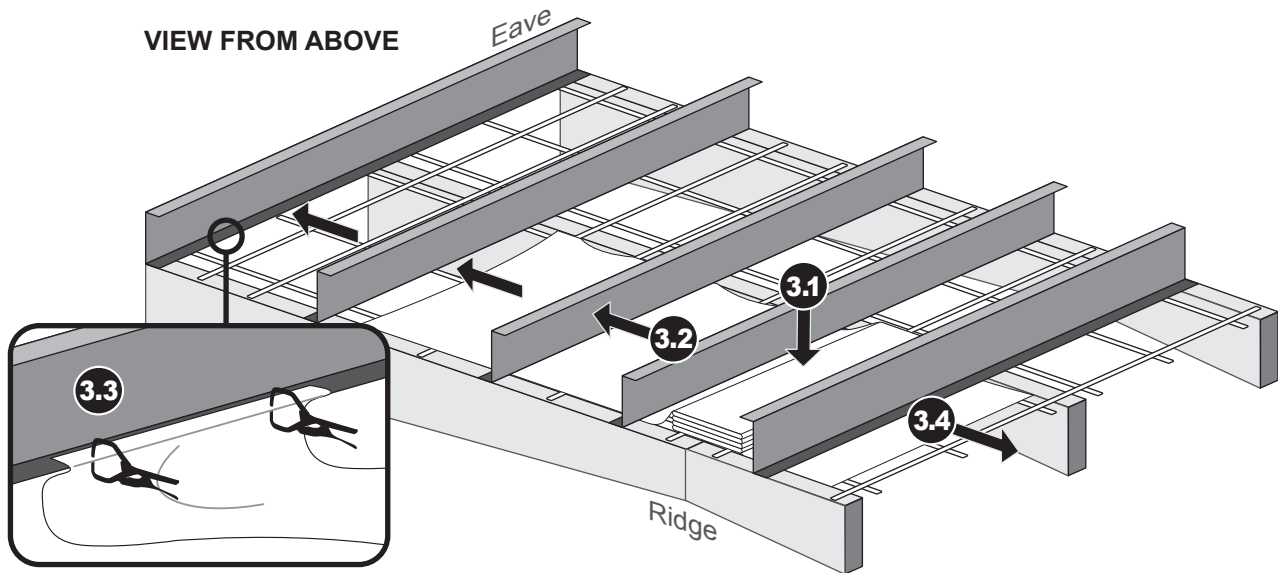

3.1 Unwrap and position the Energy Saver support fabric between the two ridge purlins of a double slope building with the finished (usually white) side facing down.

3.2 Pull one edge of the fabric beneath the purlins toward the eave strut

3.3 Temporarily attach to the eave strut with c-clamps.

3.4 Flip the fabric bundle over so that the material deploys from the top of the bundle and repeat the process, working towards the other eave strut.

NOTE: If installing on a single slope building, unwrap and position the fabric near the high side eave strut and repeat the above steps.

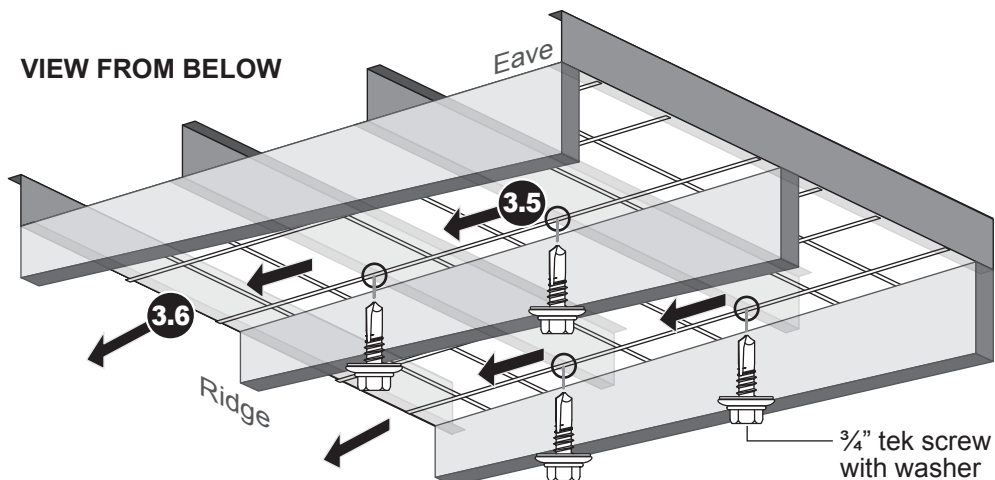

3.5 Once the fabric is smooth and square to the bay, proceed from the eave strut towards the ridge, screwing the perpendicular bands into the bottom of each intersected purlin with supplied 3/4" metal tek screw.

3.6 Continue to smooth the fabric throughout this process. If sheeting only one slope, the last fastener is installed into the far ridge purlin with a 3/4" TEK screw. If both slopes will be sheeted simultaneously, continue from the ridge down the opposing slope, stopping at the far eave strut.

3. Fabric Installation (continued)

3.7 To complete the fabric installation, remove fasteners, clips and banding at the eave strut, one bay at a time. Pull the fabric taut and apply Energy Saver adhesive or optional two-sided tape to the bottom of the eave strut and re-attach fabric using $\frac{3}{4}$ " metal tek screws and banding clips in the same holes where previously located. Adhesives must be applied to clean and dry surfaces. Finally, notch the fabric around the purlins and seal to the top of the rafters with brush adhesive or optional two-sided tape. This will be the final opportunity to tighten and smooth fabric.

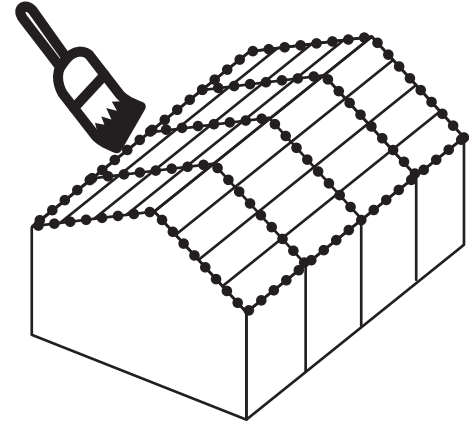

WARNING - The last 6 feet of intermediate bays does not have leading edge fall protection until adjacent bay is completed.

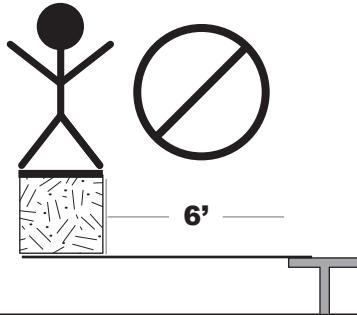

Some bay spaces may be wider than can be accommodated with a single piece of Energy Saver Fabric. If two pieces of fabric are required, please refer to the Silvercote Energy Saver fabric splicing detail in the TECHNICAL DETAILS section

4. Unfaced Glass Mineral Wool Insulation Installation

4.1 Unfaced insulation can now be installed on the liner fabric. The first/lower layer is installed within the purlin cavity and provided by Silvercote in custom cut widths, based on the building purlin spacing.

Compare metal building frame cross sections with provided jobsite cutlist to determine the optimal location of insulation rolls. Some rolls may be supplied slightly wider than building drawings specify.

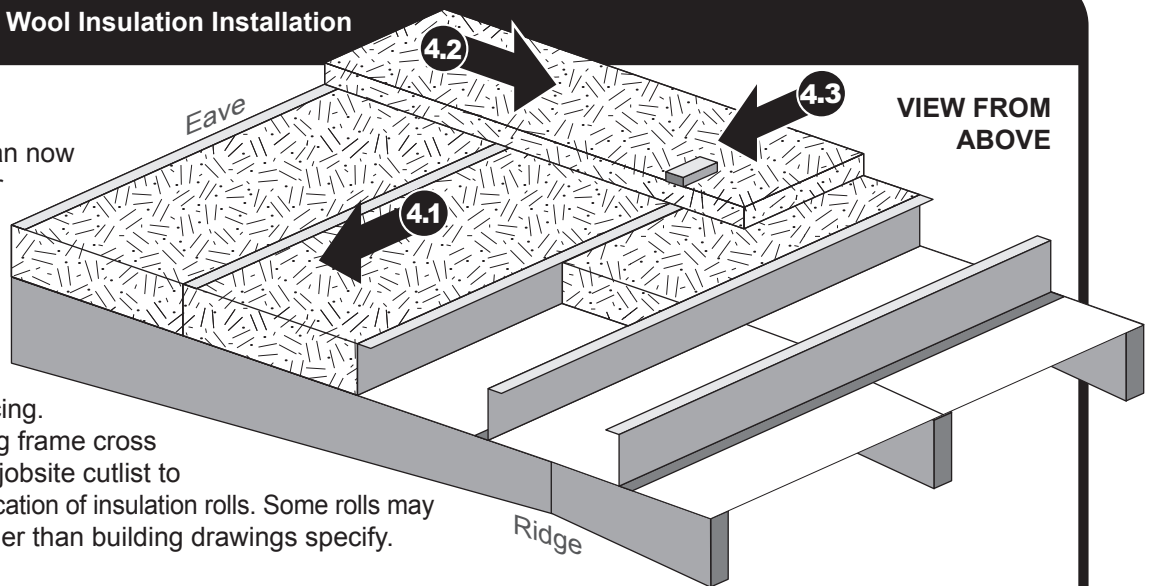

4.2 The second/top layer of unfaced insulation is now installed above the lower layer unfaced (perpendicular to the purlins), creating a thermal break below the metal roof panels.

4.3 If thermal blocks are required (not by Silvercote), install per building manufacturer's recommendations.

*Most industry experts believe that the space between the fabric and the outer metal panels should be fully filled with insulation in order to avoid potential condensation problems.

5. Metal Building Roofing Installation

5.1 Install roof steel and accessories per metal building manufacturer's recommendations.

TECHNICAL DETAILS

Perpendicular Banding Field Splice

Silvercote provides 1" white steel banding in 500' coil lengths. At times, field splicing this banding will be required due to the design width of a building.

Cross banding, installed sidewall to sidewall, can be field spliced by using a provided banding clip on the underside of a purlin. Install the bottom length of banding through the clip and drill a 3/4" TEK screw through the banding, banding clip, and through the upper length of banding into the purlin.

WARNING: Never splice banding within 10' of the eaves of a building, and never splice the cross band immediately adjacent to intermediate rafters.

NOTE: White spray paint may be applied to the banding clip to improve appearance.

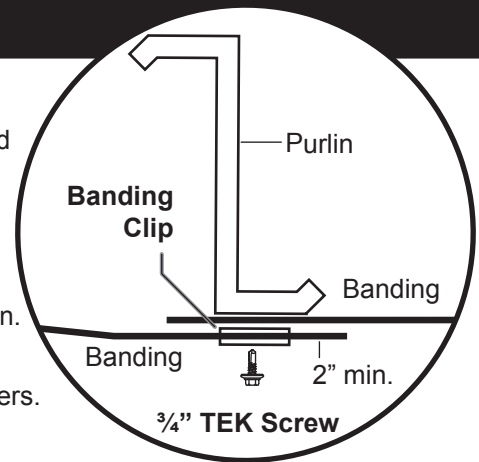

Parallel Banding Installation Supplement

If Banding rolls are not long enough to install in one piece use the following method.

- Using a banding clip, install end of banding roll #1 to one side of the intermediate roof beam.
- Using a banding clip install end of banding roll #2 to the other side of the same roof beam. End at end wall.

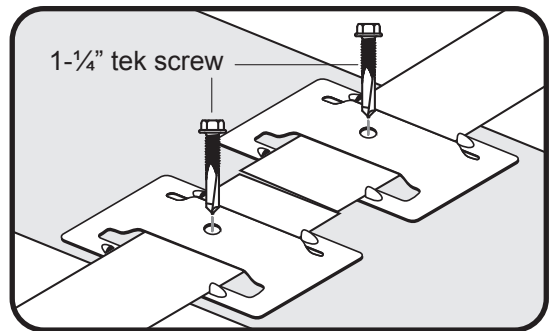

Fabric Field Splice

In some instances, where a building is too wide for the Energy Saver FP fabric to be installed from eave to eave in one full piece, field splicing may be required. On a double slope building, this can be done at the first purlin down from the ridge. On a single slope building, the splice will be made at a pre-determined purlin, mid-slope.

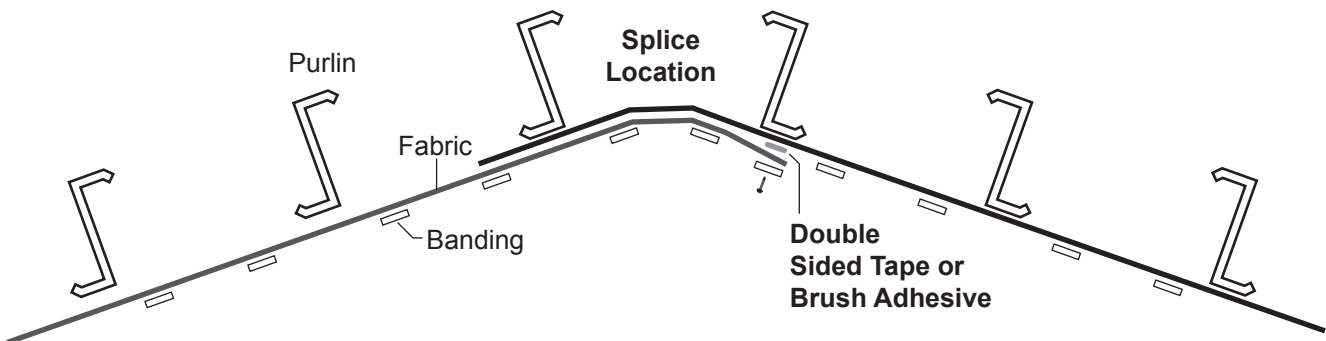

TEK SCREW INSTALLATION GUIDELINES:

A standard screw gun with a depth sensitive nosepiece should be used to install Tek fasteners. For optimal fastener performance, the screw gun should be a minimum of 6 amps and have an RPM range of 0-2500 (maximum 1800 RPM is recommended for Teks 5 fasteners, which are the fasteners supplied for use with this clip).

Overdriving may result in torsional failure of the fastener or strip out of the substrate. The fastener must penetrate beyond the metal structure a minimum of 3 pitches of thread.

TECHNICAL DETAILS (continued)

BANDING CLIP DETAIL (U.S. Patent No. 8,015,769)

1. When installing both the cross banding and longitudinal banding, insert the 1" white steel banding through the Energy Saver Banding clip, leaving approximately 4" to 6" of extra banding. The fastener and the center fastening point of the banding clip must be flush with the surface of the beam and fully tightened (torqued to a minimum 150 in. lbs.). This will yield proper pull out strength by correctly compressing the banding against the steel framing.
2. Where the bands intersect the endwall rafters, drill the provided 1 ¼" TEK screw down through the clip, then through banding and into the building's endwall rafter.
3. Where the bands intersect the eave struts, drill the provided ¾" TEK screw up through the clip, then through the banding and into the eave strut. Any cross band directly adjacent to a rafter must be spaced EXACTLY 6" from rafter edge. Remaining cross bands should be spaced on equal centers, no greater than 60" apart.

Note: Clips may be painted white to match the banding and underside of the Energy Saver FP System fabric if desired.

Note: The banding clip should be installed at the origination and termination point of each run of white galvanized steel banding around the perimeter of the building. The clips should be positioned so that the screw will first penetrate through the clip and then the banding using only one fastener. Do not install additional fasteners through clip or directly through banding. Each clip should be tightened as securely as possible (torqued to a minimum 150 in. lbs.), without stripping the threads. Longitudinal bands should be secured at endwall rafters only. Do not use fasteners to secure longitudinal bands to any interior rafters.

FLANGE BRACE ATTACHMENT

Many metal building manufacturers can accommodate requests for a modified attachment of the flange braces, which helps minimize penetrations to the Energy Saver FP fabric. We suggest you check with your supplier prior to ordering your building to see if something like the accompanying detail is available. Note that the flange brace to purlin connection is a critical detail that cannot be modified without approval from a qualified engineer.

