

SAG-N-BAG ROOF INSTALL INSTRUCTIONS

FOR NEW CONSTRUCTION

Read the entire instructions before you begin.

STEP 1 — IDENTIFYING YOUR ROLLS

BEFORE BEGINNING READ THE CUTLIST THOROUGHLY. THIS WILL GIVE IMPORTANT INFORMATION NEEDED FOR PROPER INSTALLATION.

Verify that the material provided matches with the cutlist. If there are any discrepancies NOTIFY SILVERCOTE IMMEDIATELY. When installing insulation inspect rolls for any defects. If defects are detected NOTIFY SILVERCOTE (IMMEDIATELY BEFORE INSTALLING.) Using the provided detailed cutlist and color coded bag tags locate the proper insulation for each roof slope.



Example of roof cutlist and corresponding roll label:

Building #1: 45' W x 80' L x 16' Eave 2:12 Pitch

Roof Starter Roll 48" x 48"	Roof Primary Roll 72" x 48"	Roof Primary Roll 72" x 48"	Roof Primary Roll 72" x 48"	Roof Primary Roll 72" x 48"	Roof Primary Roll 72" x 48"	Roof Primary Roll 72" x 48"	Roof Primary Roll 72" x 48"	Roof Primary Roll 72" x 48"	Roof Primary Roll 72" x 48"	Roof Primary Roll 72" x 48"	Roof Primary Roll 72" x 48"	Roof Finish Roll 48" x 48"
-----------------------------	-----------------------------	-----------------------------	-----------------------------	-----------------------------	-----------------------------	-----------------------------	-----------------------------	-----------------------------	-----------------------------	-----------------------------	-----------------------------	----------------------------

Roof Rolls Are Identified with Blue Tags

Where the colors go:

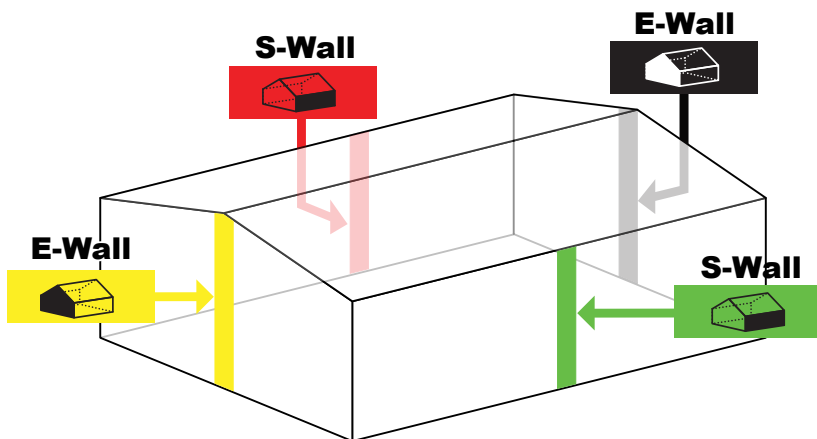
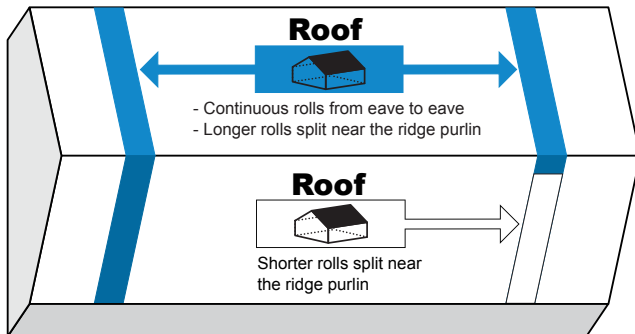

Detailed roll labeling

Silvercote™
A SERVICE PARTNERS COMPANY

Ship To: Building Supply South
232 Riverchase Rd.
Osburn, GA 31555

Order & PO Number: 155635-00

Roll Details: Roof Primary Roll

72" x 48'

6" R-19 METAL BUILDING INSULATION VWR PLUS (2-3" TABS)

Roof

Sequence: 1 of 12

silvercote.com | Customer Service | 844-232-8731

See back for details.

STEP 2 — DETERMINE YOUR TAB

To meet increasing energy codes Silvercote recommends sealing all insulation seams by using our one - 6" tab with double sided tape pre-applied. However, Silvercote offers many different tab and tape configurations. Shown here are two options for installing your faced insulation.

2.1 Silvercote's most popular MBI roof insulation has one - 6" tab or two - 3" tabs. See the cutlist and labels to determine which tabs were provided.

If you have one - 6" tab see **3.1**
If you have two - 3" tabs see **3.4**

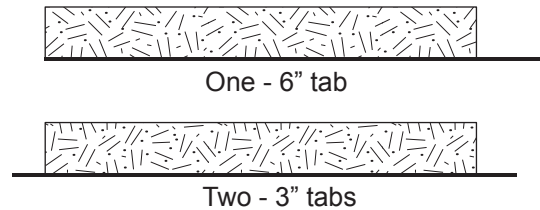

STEP 3 — ONE 6" TAB

FACTORY APPLIED DOUBLE SIDED TAPE

3.1 If one - 6" tab is supplied, unroll with the tab facing in the direction you are roofing. Unroll the next roll overlapping the facing onto the tab of the previous roll.

3.2 If your rolls were ordered with double sided tape applied to the tabs, remove the paper backing now.

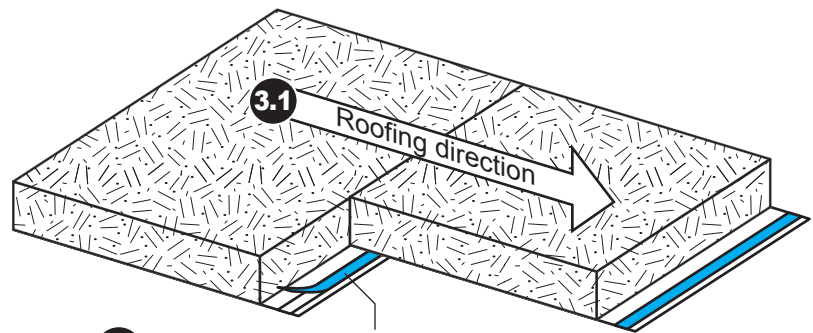

3.2 Double sided tape applied to facing tab

WITHOUT TAPE

3.3 If one - 6" tab is supplied, unroll with the tab facing in the direction you are roofing. Unroll the next roll overlapping the facing onto the tab of the previous roll.

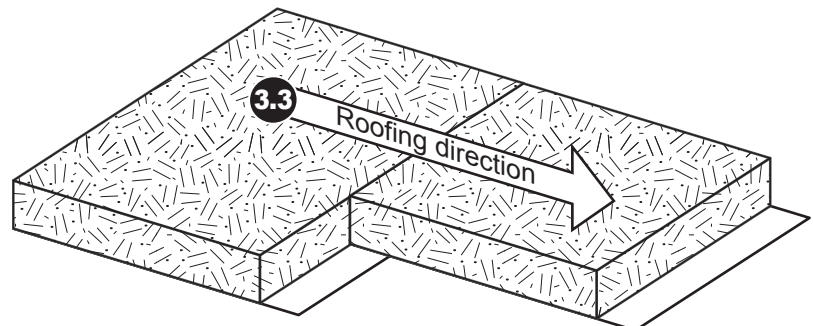

STEP 3 (CONTINUED) — TWO 3" TABS

3.4 If two - 3" tabs are supplied, a plier stapler should be used to connect adjacent rolls of insulation.

Note! Caution should be taken not to staple too close to the base of the tabs as the staples may pull out during the sheeting process. This could result in undesired appearance and a poor vapor seal.

3.5 At the joined seam, pull the tabs upward and staple approximately every 8". The initial staples should be placed $\frac{1}{2}$ " from the end of the tabs.

3.6 Fold the joined tabs over and staple in between each original staple, approximately every 4". Tuck the completely sealed tab back into the joint.

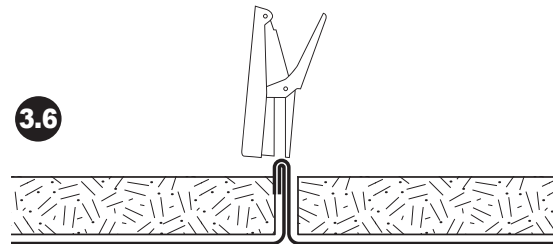
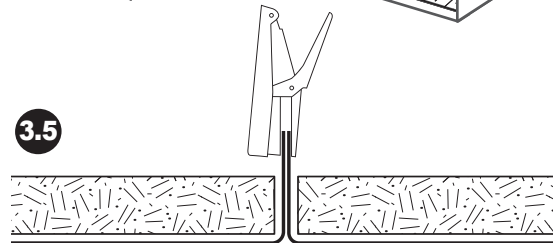
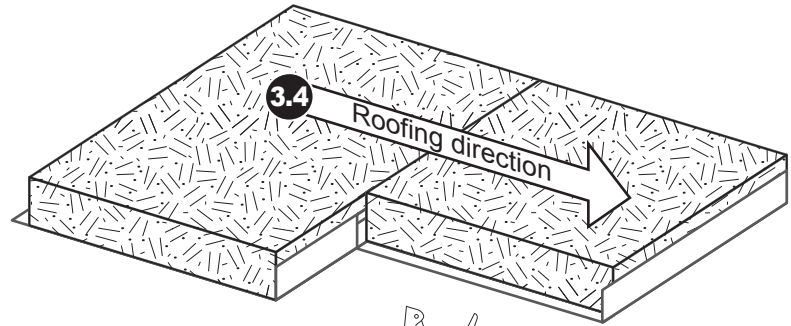

STEP 4 — THE PROPER PROCESS

- 4.1** The first layer (perpendicular to the purlins) of Roof insulation should be installed in one piece from eave strut to eave strut.
- 4.2** Roofs may require more than one roll to span the roof. The first roll should be installed across the ridge to the top purlin on the opposite slope. A splice will need to be made when installing the rolls for the opposite slope. Refer to 6.1 Roof Splice at the end of these instructions.

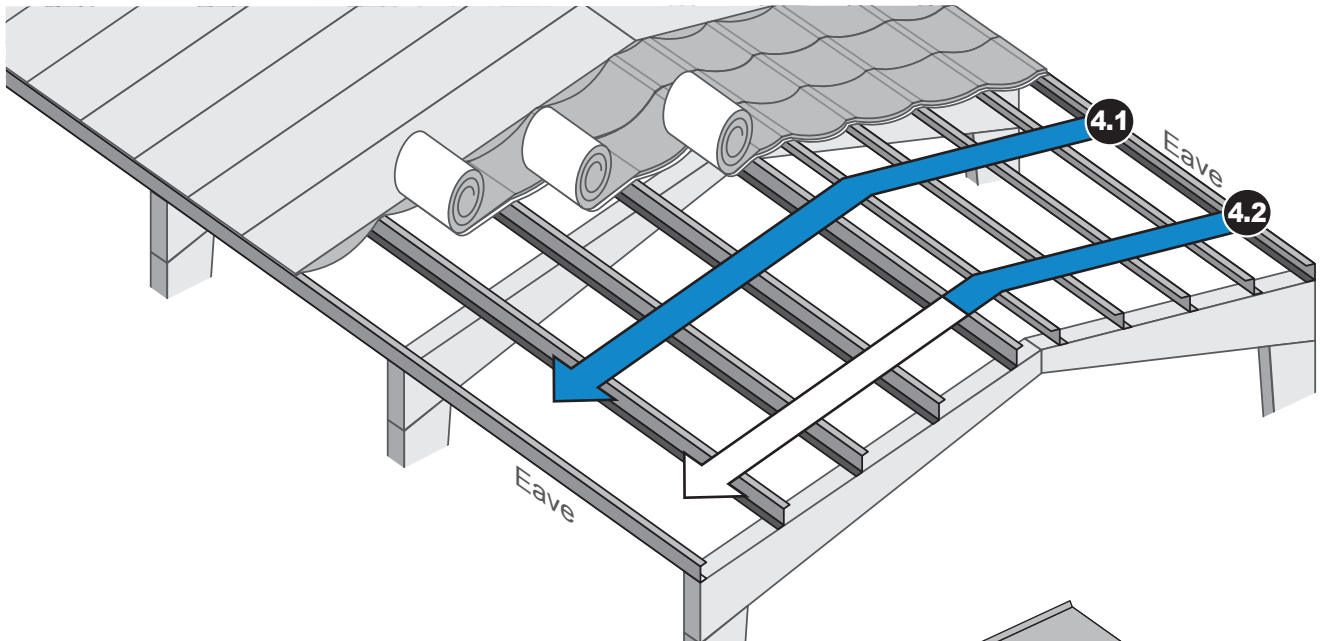

- 4.3** A starter roll's purpose is to provide a leading edge of the insulation beyond the sheeting in the roofing direction. Check your cutlist to see if a starter roll was ordered. If all rolls are the same width a starter roll can be created by field cutting a roll to 1 foot wider than the starting roof panel. Care should be taken to keep the cut as straight as possible.

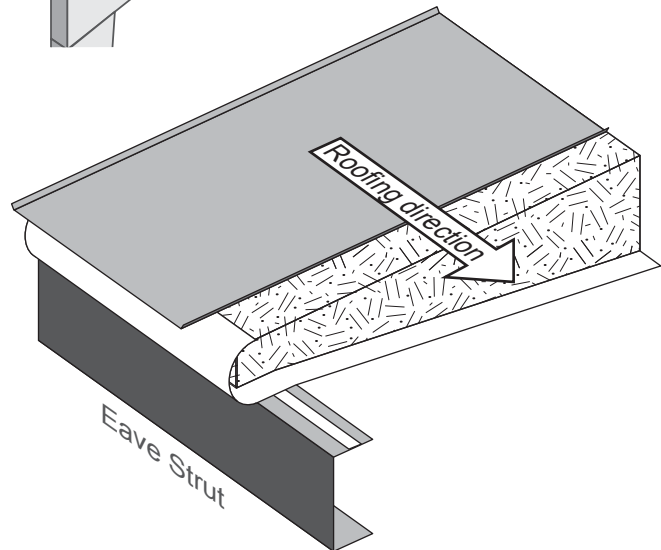

STEP 5 — INSTALLING THE PERPENDICULAR LAYER OF INSULATION

- 5.1** Use double sided tape to attach the insulation roll to the eave strut allowing at least six inches of overhang. C clamps may need to be used to temporarily maintain this connection until roof sheets are in place.
- 5.2** Unroll insulation to the other eave of the building allowing similar overhang. Rolls should have been ordered with enough extra length to allow sag between the purlins to accommodate the top layer with minimal compression.

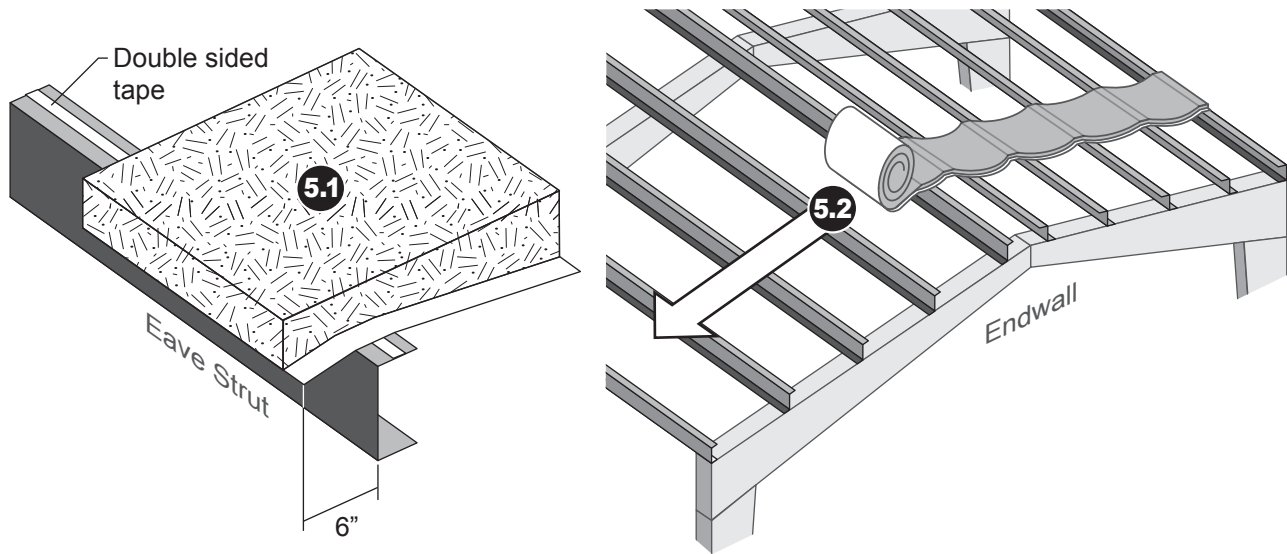

Note! It is important to keep the insulation under proper tension as the roof panels are installed. If excess sag is developed and the top of the insulation is not in contact with the roof sheets condensation can occur. If there is too much tension overcompression can occur which could diminish thermal performance.

- 5.3** Before installing roof panels carefully trim 6" of insulation off the end of the facing and wrap the facing around the top of the fiberglass. This helps prevent water 'wicking' into the building.

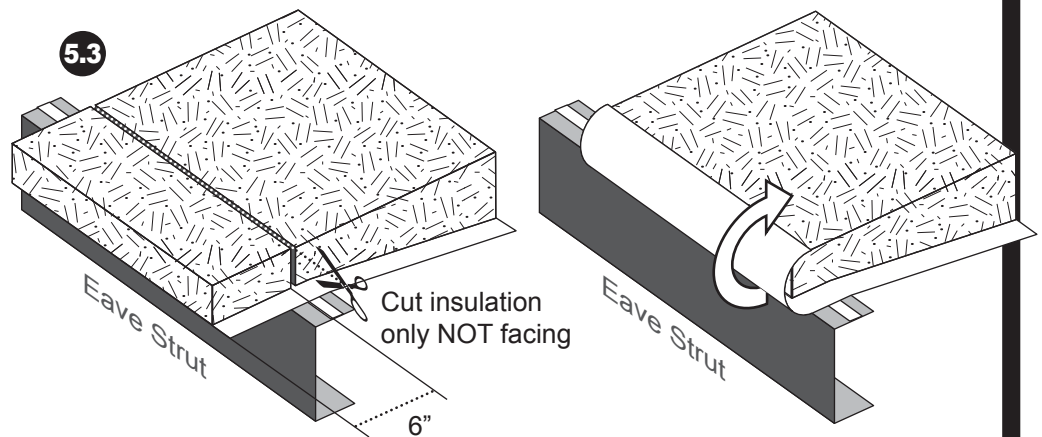

STEP 6 — INSTALLING PARALLEL LAYER OF INSULATION

6.1 Insulation is provided in standard 5' wide rolls. It is rolled out between the purlins, supported by the laminated layer. Rolls can be cut to fit the purlin space on site if needed. It should be narrower than the purlin space so both layers are not compressed on top of the flange. Care should be taken to ensure the top layer is not compressed over the purlin flange. Thermal blocks, which are typically provided by the metal building supplier are placed on top of the purlin flange to minimize thermal short circuiting.

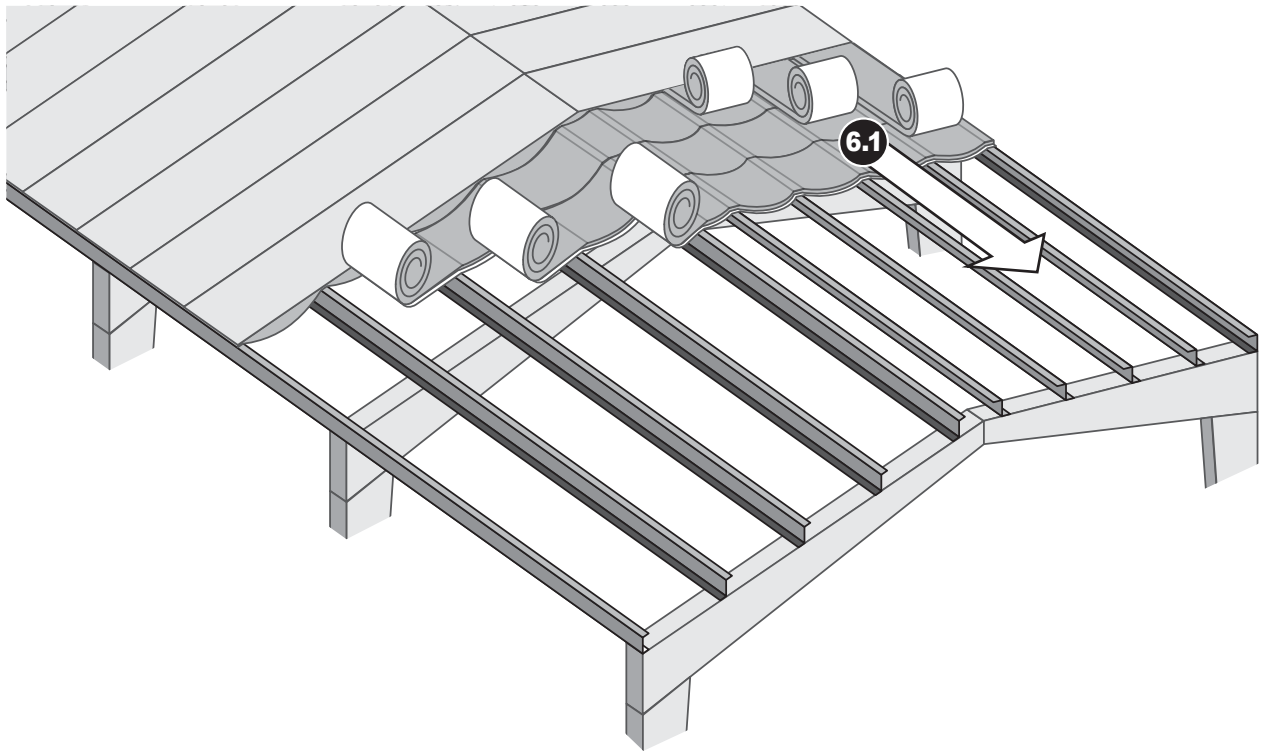
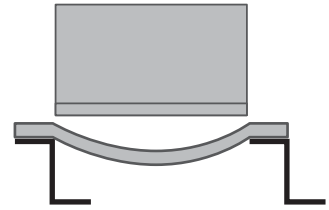

6.2 Install roof panels. If thermal blocks are supplied they should be installed between the insulation and roof panels.

STEP 7 — ROOF SPLICE

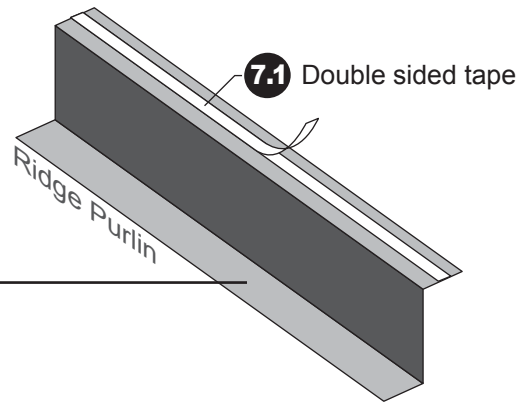
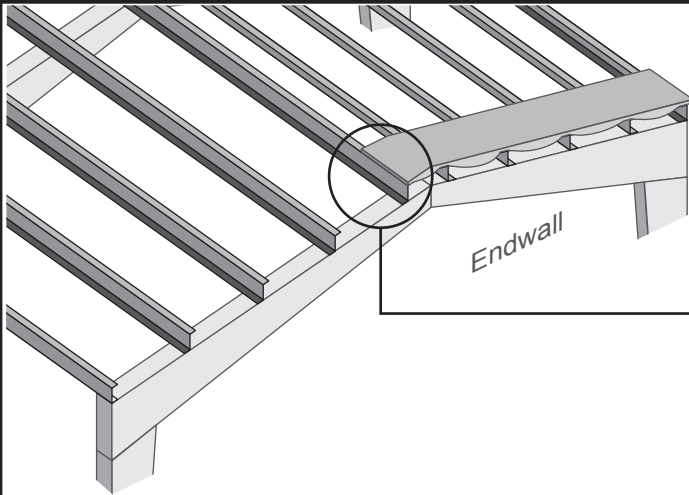

- 7.1** Before installing the roof panels on the second slope apply double stick tape to the top of the highest purlin.

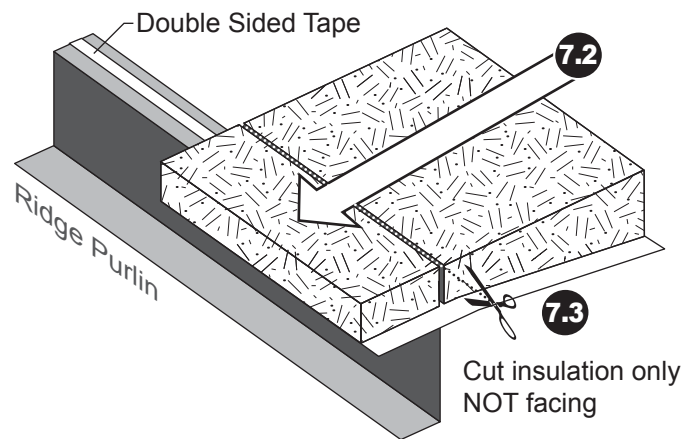

- 7.2** Stretch and tape down end of long roll.

- 7.3** Using care not to cut the facing, trim off excess insulation and remove fiberglass from above the purlin.

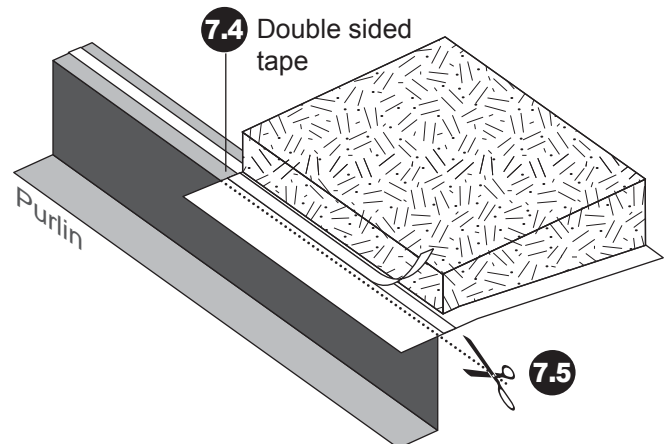

- 7.4** Apply double stick tape where insulation was removed.

- 7.5** Trim excess facing flush with upward flange of the purlin. Remove paper backing from tape.

- 7.6** Pull the secondary roll of insulation up to the splice location and apply roll facing to the double sided tape, pressing firmly to secure connection.

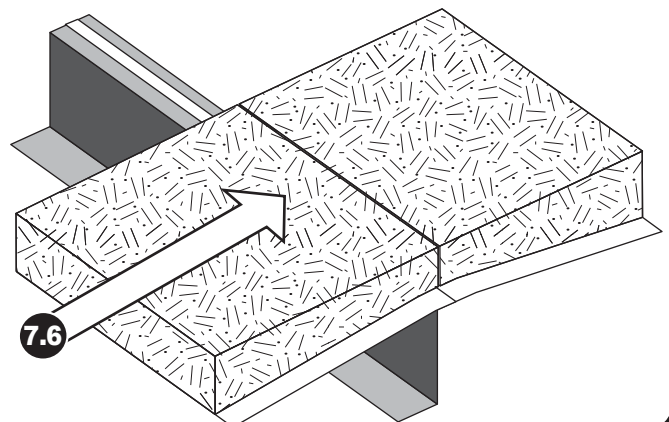

STEP 8 — RIDGE INSULATION

There may be a separate assembly used to attach the ridge cap. This may create a separate air space which could lead to condensation. Make sure to completely fill this space with insulation. Consult your cutlist to see if a roll was ordered.

