



Retro Roof Install Instructions

FOR RETROFIT CONSTRUCTION

Read the entire instructions before you begin.

Before you begin:

Locate the shipping pallet that contains the Energy Saver™ System installation packet. The pallet will be indicated by a marked sticker.

It will contain:

- *Jobsite Cutlist* - Used to inventory all Energy Saver fabric/components and unfaced insulation rolls. Additionally, it will indicate where the products are to be installed on your project.
- *Installation Instructions* - These will be used to explain the steps involved with the Energy Saver Retro system.
- *Packing Slip(s)* - The carrier's paperwork detailing delivered materials.

Please be sure to inventory all materials and mark any shortages.

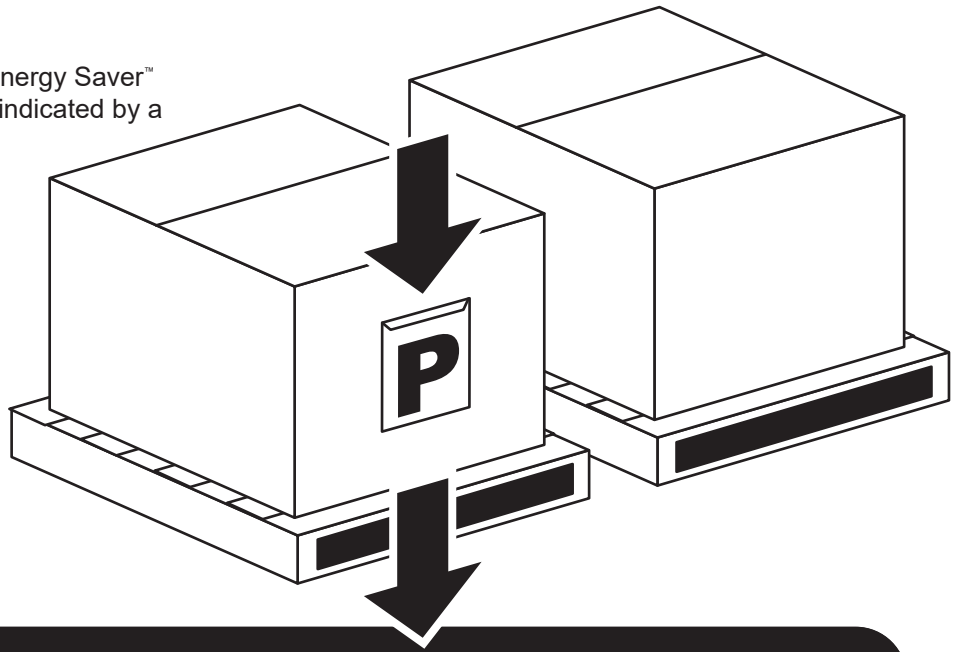

The pallet(s) will also contain the accessories needed for the successful completion of the fabric liner system:

1¼" metal tek screws

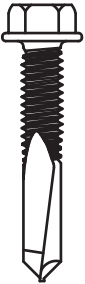

¾" metal tek screws with washer



Insul-hold

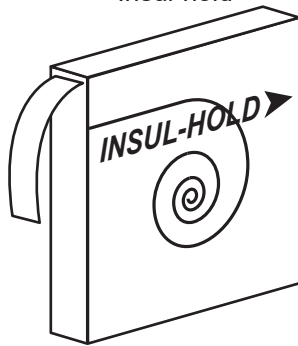

Patch tape

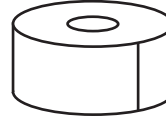

Energy Saver adhesive tape



Energy Saver fabric (bagged and labeled with size and installation locations)

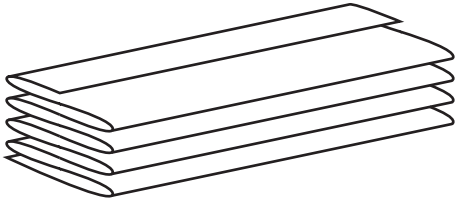

Energy Saver banding dispenser

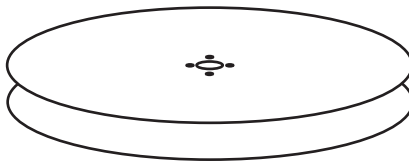

Energy Saver banding

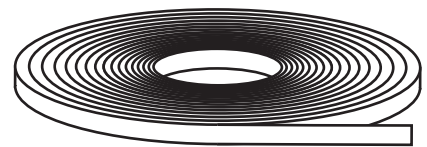

WARNINGS

- ❗ It is recommended to only use this system when there is existing insulation above the purlin. This provides a frost break and helps guarantee that the insulation will stay in contact with the roof deck. If this layer is not present; consult your Silvercote sales representative for more details. Always completely fill the cavity.
- ❗ If project includes Energy Saver walls, special consideration may be required at eave strut. See Energy Saver wall install instruction details.

ROOF – STEP 1. Perforating the vapor barrier

- 1.1** To eliminate a double vapor barrier, using any sharp object such as utility knife or wall paper perforation tool, perforate the facing of existing insulation above purlins. Cut a one foot slice approximately every 3' of each purlin space.

VIEW FROM BELOW

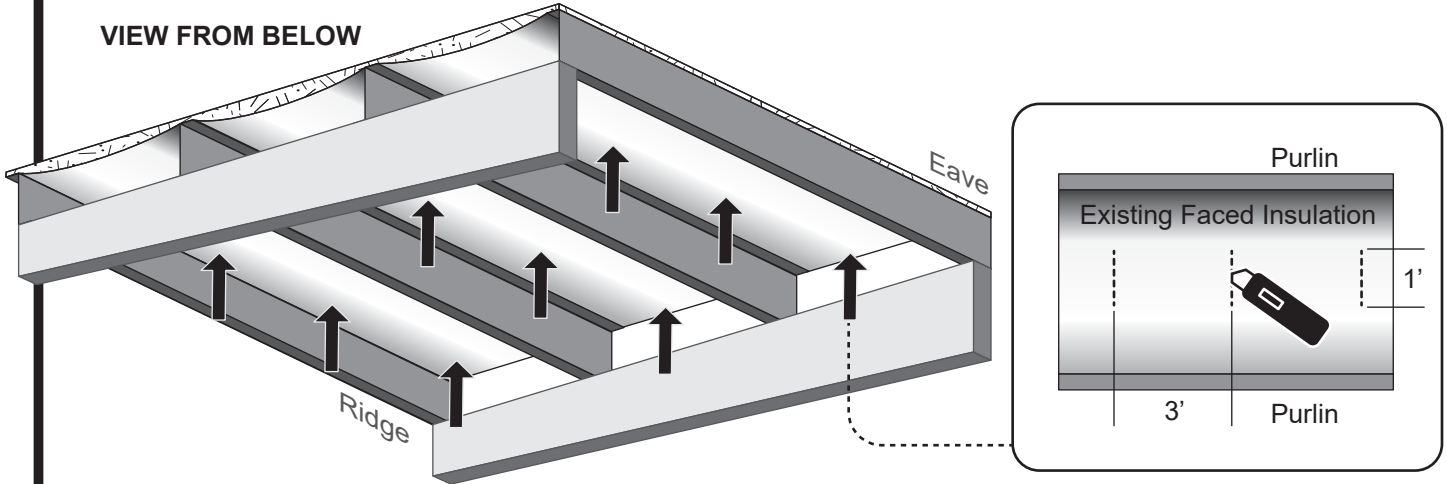

- 1.2** Remove any interference (electrical conduit, lights, flange bracing, etc.) from the bottom flange of secondary structural in each bay as installation progresses.

ROOF – STEP 2. Banding installation for insulation support

- 2.1** Install 1" white steel banding 60" on center perpendicular to the purlins from eave strut to eave strut.

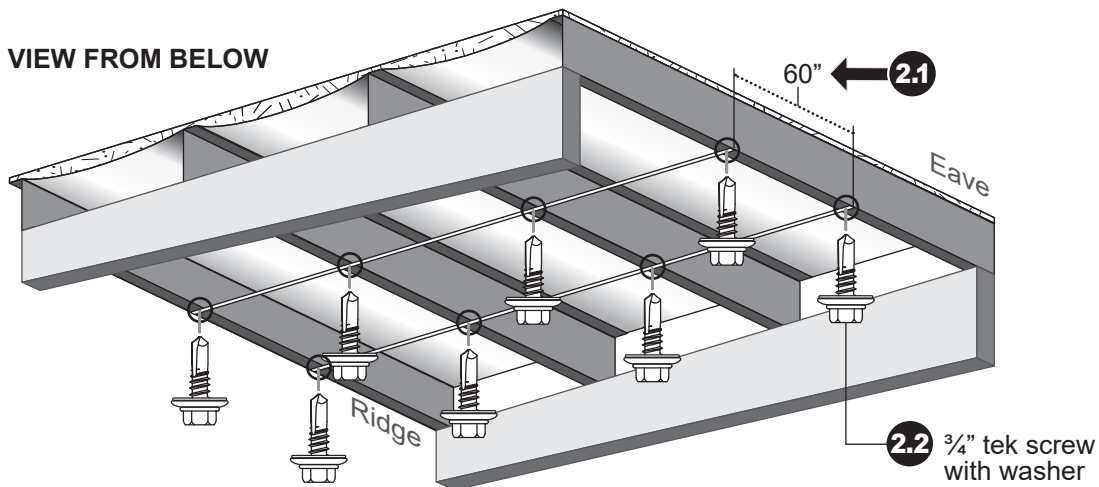

- 2.2** Fasten banding with one 3/4" TEK screw at the intersection of each purlin. The purpose of the first set of perpendicular bands is to support the insulation.

ROOF – STEP 3. Insulation Installation

3.1 Compare the widths of unfaced insulation provided with the actual purlin spaces. Locate and install each roll of insulation in the appropriate purlin space.

3.2 Unfaced insulation can now be installed parallel to the purlins above the perpendicular bands within the purlin cavity. It may be necessary to remove some fasteners to allow adequate space to install the insulation. Fasteners should be replaced as each purlin space is filled.

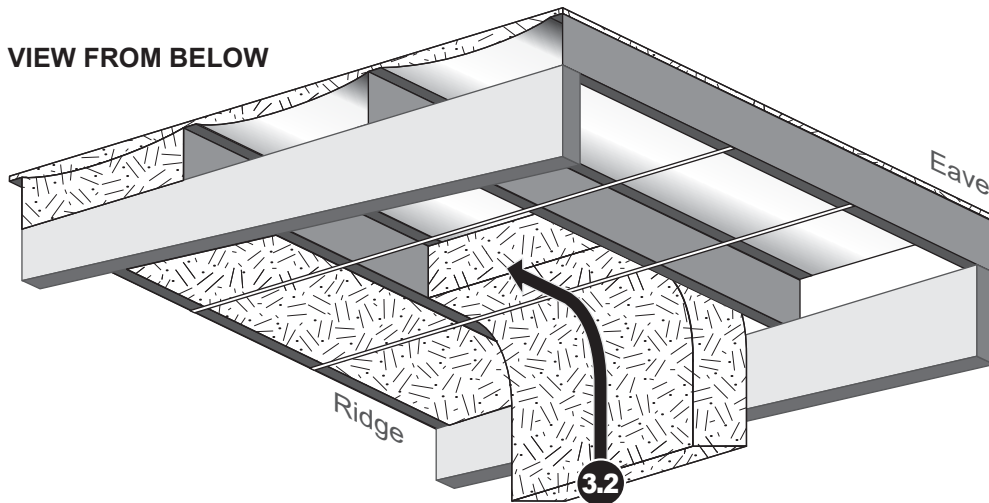

3.3 If there are obstructions in the purlin cavity it may be necessary to cut the unfaced insulation during installation to eliminate compression. Make sure this does not create voids.

ROOF – STEP 4. Banding installation for fabric support

4.1 A second set of perpendicular bands should now be installed on 60" centers spaced evenly between the previously installed bands.

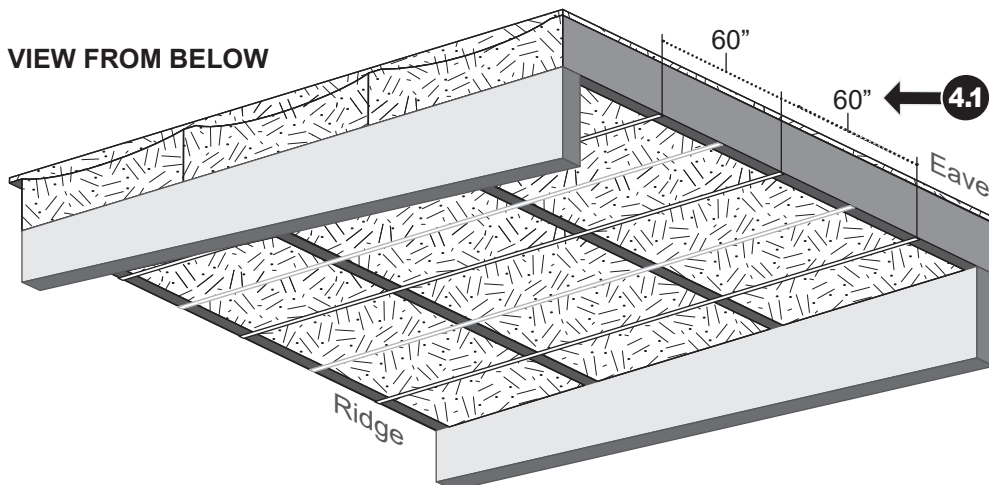

ROOF – STEP 4. Banding installation for fabric support (continued)

4.2 Fasten each band with a $\frac{3}{4}$ " TEK screw to the bottom of the eave strut. Pull the bands to the far ridge purlin (hand tight) and fasten with a $\frac{3}{4}$ " TEK screw to the ridge purlins. Continue to pull the banding to the opposite eave strut and fasten. For single slope buildings the banding is installed from low to high eave strut.

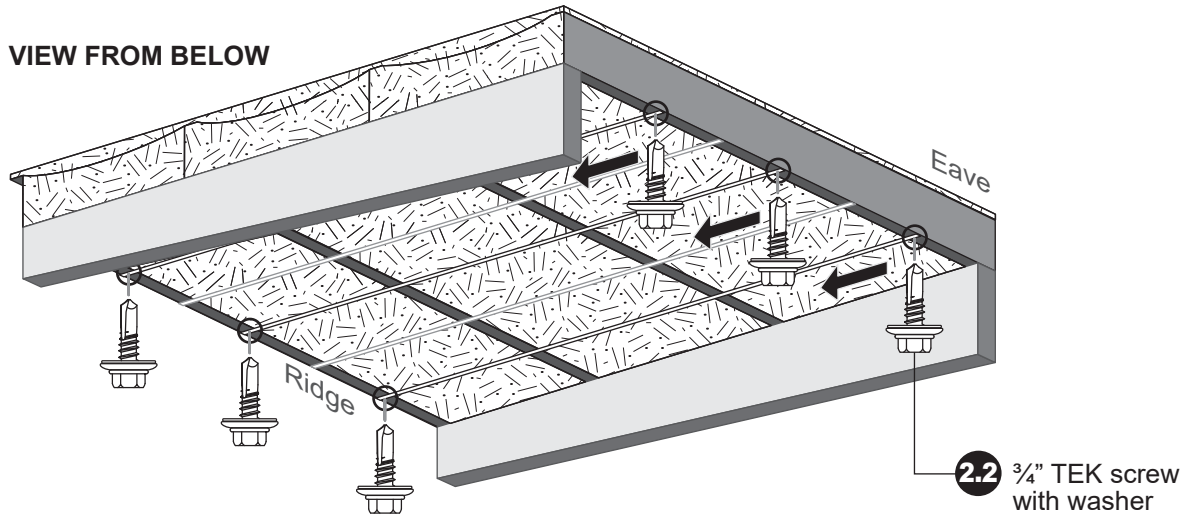

ROOF – STEP 5. Energy Saver fabric installation

5.1 Locate proper panel of Energy Saver fabric for each bay. Each panel will be in a separate bag with the location noted on the label. Remove Energy Saver fabric bundle from bag and place it in the center of the bay on the second set of perpendicular bands just below the ridge or high wall eave strut on single slope buildings. Unfold the bundle from frame to frame in each bay of the building. There should be approximately six inches of extra facing at each frame line. Place bundle so that the fanfolds can be deployed from the top of the bundle. The white or black side of the facing should face down when deployed. Pull one end of the Energy Saver fabric down slope to the eave strut. Square the Energy Saver fabric and temporarily clamp to eave strut.

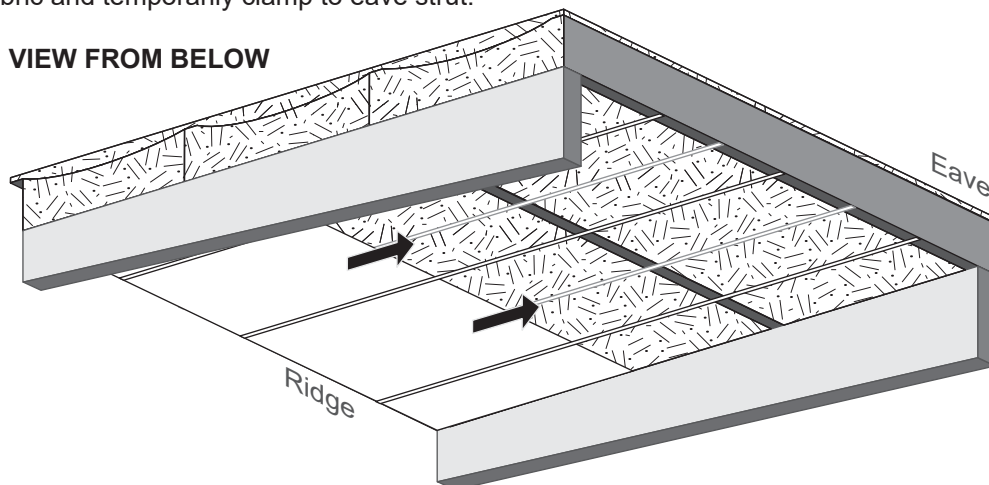

ROOF – STEP 5. Energy Saver Fabric installation (continued)

5.3 Once the Energy Saver fabric is square and smooth, beginning at the eave strut, tighten banding and fasten to each intersecting purlin using provided $\frac{3}{4}$ " TEK screws. On single slope buildings, attach to low and high eave strut. For double slope, when reaching the ridge continue down to the opposite eave.

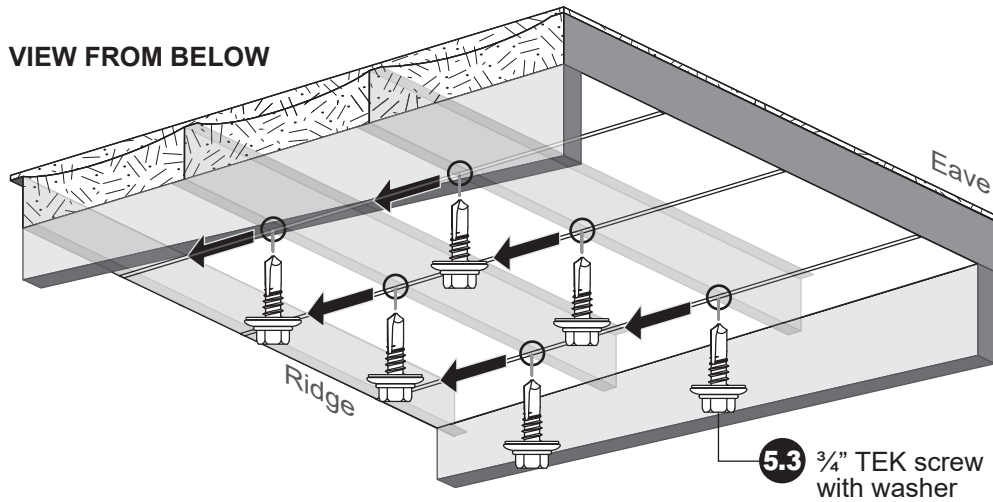

5.4 At the rafters bring fabric below bottom flange and attach with Energy Saver double sided tape. Using $1\frac{1}{4}$ " fasteners at 36" – 60" on center depending on installer preference, apply banding for mechanical attachment to the bottom of the frame. Trim excess fabric for a clean neat appearance.

5.5 Remove clamps from eave struts. Use the two sided tape to seal perimeter of fabric.

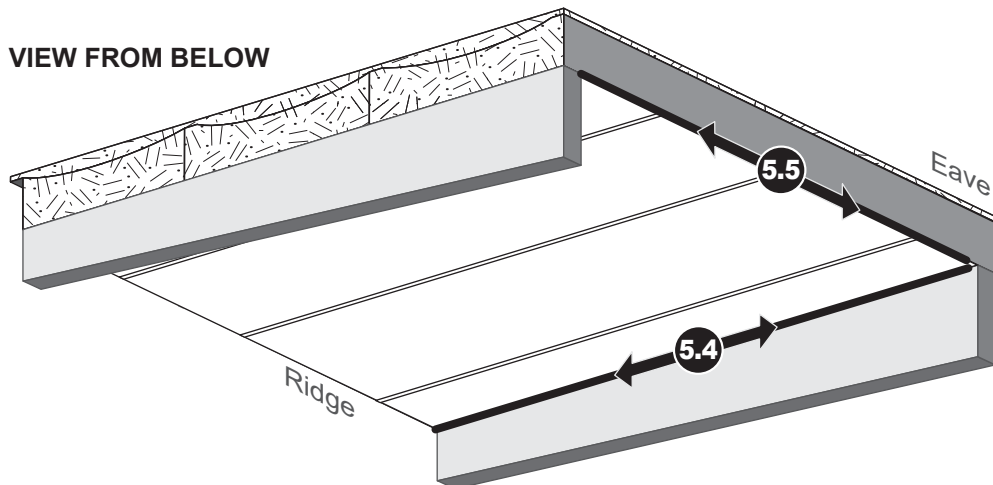

NOTE: If there are flange braces present which will penetrate the fabric special care must be taken to seal these and any other penetrations such as mechanical, electrical and sprinkler.